



CHANGE YOUR WATER CHANGE YOUR HEALTH



info@snowis.in



Integrating Technology, Design, and Quality into a Unified Entity

About Snowis:

We are committed to delivering premium water products tailored to the diverse needs of businesses, offices, and households.



Snowis Water Goal

Our goal is to offer customers top-notch water solutions and cutting-edge technology, fostering healthier lifestyles and living environments.



Snowis Water Core Values

We prioritize delivering the purest and healthiest water through our products, adhering to the belief that **"Quality is the core of an enterprise's strength."** Our environmentally friendly products contribute to reducing energy consumption by extending appliance life cycles.

About Alkaline Water

Alkaline water is more than just a beverage; it embodies a lifestyle choice that people should incorporate into their daily routines. Distinguished by its higher pH level compared to regular water, alkaline water is crafted by infusing essential alkaline minerals like calcium, magnesium, and potassium.



INNOVATIVE WATER TECHNOLOGY

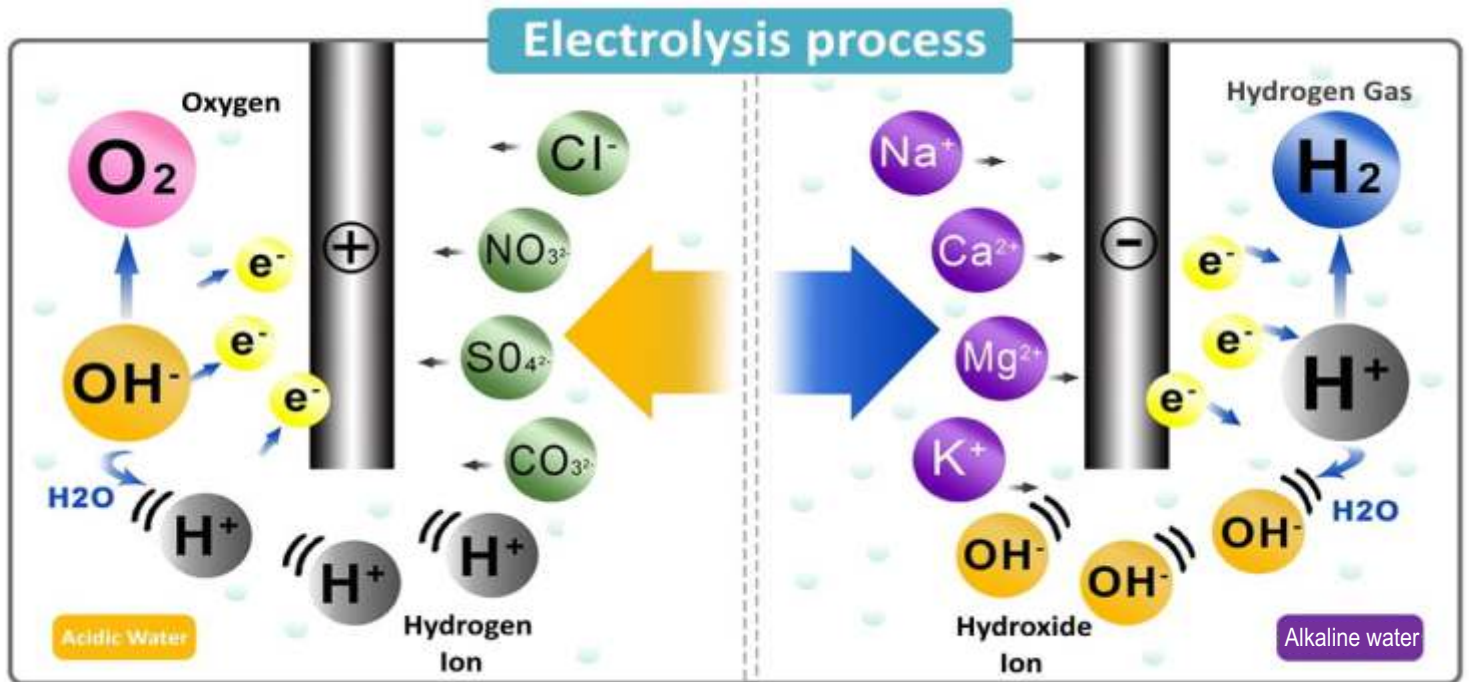

An Electrolytic Cell equipped with Electrode Plates of Titanium coated with Platinum is used for ionization process

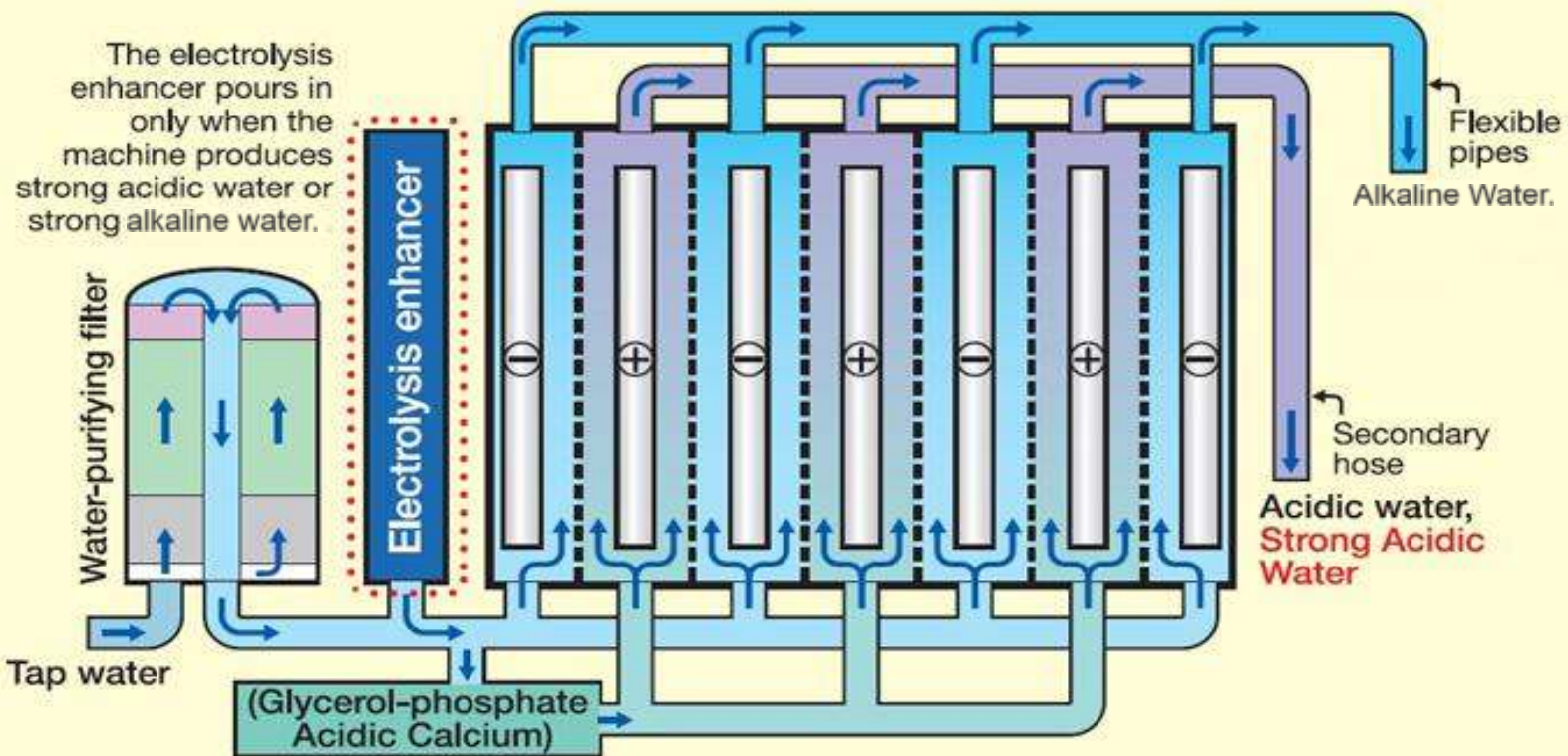

OXIDATION

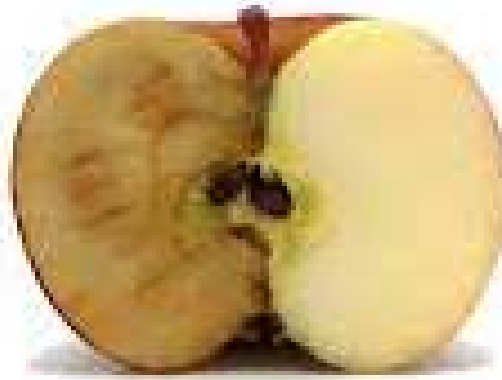

NO
OXIDATION

Oxidation Scale

- ORP (mv)

+ ORP (mv)

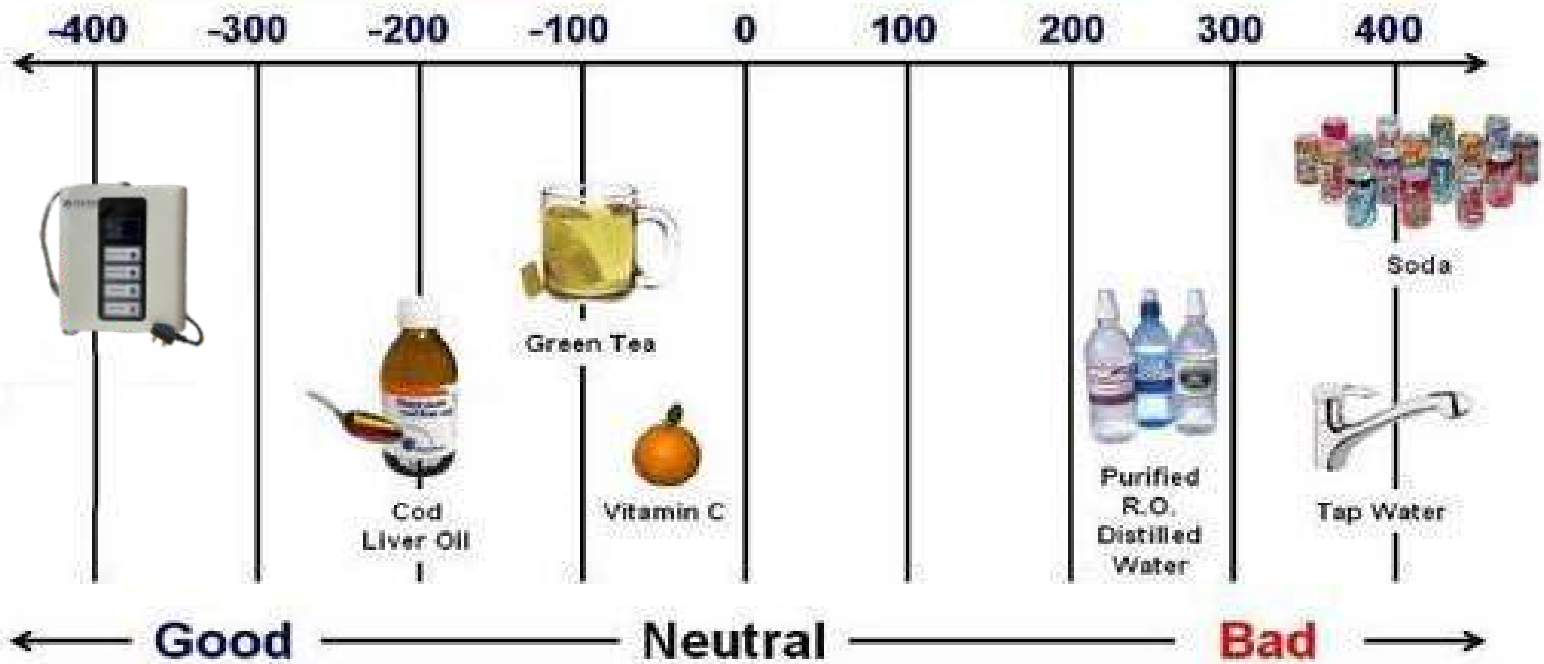

Alkline Water (Creates 3 Properties into your Water)

ANTI-OXIDANT

Fights with Oxidative Stress

ALKALINITY

Fights with Acidic Stress

MICRO-CLUSTERED

Fights with Dehydration



USES OF ALKALINE WATER ACCORDING TO pH LEVEL



Alkaline Water - 8.5 – 9.5 pH

- 🚰 Ideal for Drinking & Healthy Cooking
- 🚰 Electrolyzed hydrogen-rich water enhances taste & aroma

Clean Water - 7 pH

- 🚰 Filtered, neutral water, free of chlorine, rust & impurities
- 🚰 Suitable for making baby formula for infants
- 🚰 Ideal for medication



Beauty Water - 4.5 – 6.0 pH

- 🚰 Perfect for Skin & Hair Care
- 🚰 Beneficial for plants
- 🚰 Ideal for pet care
- 🚰 Useful for house cleaning

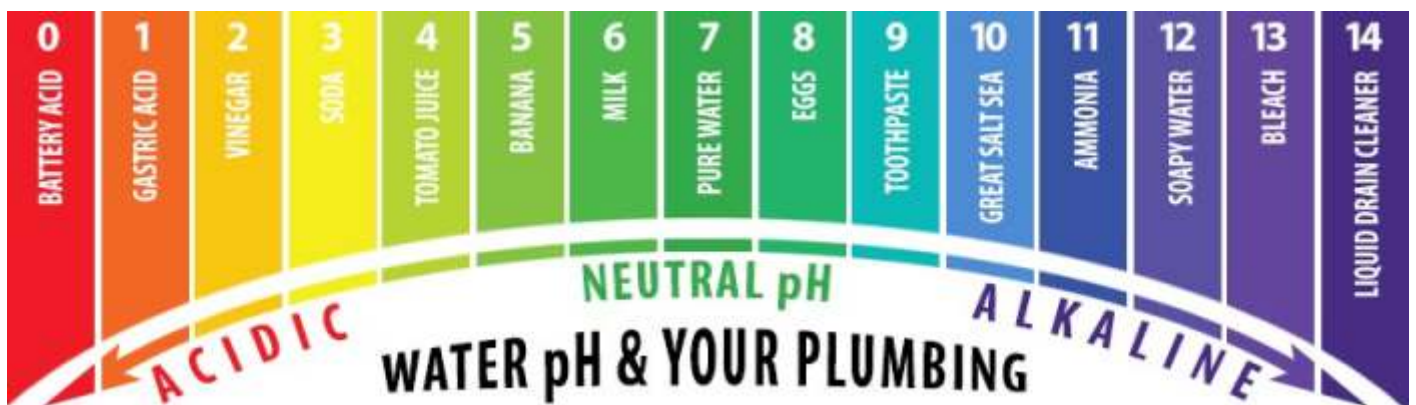

What Can Alkaline Water Do For You?

Alkaline water can neutralize the acidity of the body caused by stress, modern diet, air pollution, and many bottled water.

Restores body function by cleaning your cells from the inside out.

Improves your immune system function to help you fight diseases.



A higher pH in the body reduces the need for fat and cholesterol to protect the body from damaging acids.

Improves the body's absorption of essential nutrients.

Alkaline water is negatively charged and an "antioxidant". Antioxidants reduce cellular and DNA damage caused by free radicals

Increases blood oxygen levels to deliver more energy to the body.

Micro Clustering Properties of Alkaline Water

Alkaline water super- hydrates the body

Regular H₂O Cluster

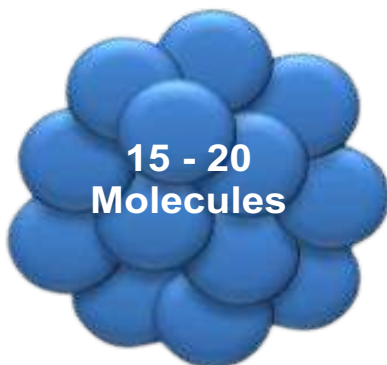

15 - 20 Molecules

Bigger water clusters hinder efficient absorption by the body.

4 - 6 Molecules

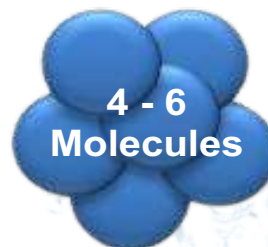

Alkaline H₂O Micro-Cluster

Micro-clusters enable enhanced penetration and facilitate easier absorption.

Characteristics of Alkaline Ionized Water

* pH of water is greater than 7

* Antioxidant

* ORP between -100mV to -600mV

* Micro Clustered Molecules

* Boost Mineral Absorption

* High Hydrogen Concentration

* Presence of Calcium, Silica, Potassium and Magnesium



5 Major Benefits of Drink Hydrogen Rich Water

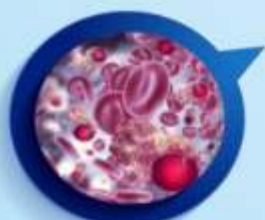

Cancer resistance



Anti-aging



Weight Loss



Colon-cleansing



Immune System

Super Anti-Oxidant

10 Cups
Green Tea



800 Grm
Blue Berries



3 Kg
Broccoli



40
Bunches Spinach



30
Carrots



750
Bananas



516
Apples



3.5Kg
Pumpkin



1 Glass
Alkaline Water



1 litre
Alkaline Water

SWK 41

The Ultimate Health Fit Model

Introducing Snowis Water Ionizers – the ultimate solution for transforming tap water into ionized water, perfect for drinking and acidic water ideal for cleaning. Our advanced technology elevates ordinary water, delivering a refreshing taste along with a range of health benefits.

Product Specifications

Screen	:	TouchPad Display (100*50mm)
PH Level	:	4.5-10.5
Input TDS	:	50-150
Wattage	:	0-400 (W)
Water Flow	:	40-50 LPH
Ease of Use	:	Fully automatic, simple to operate
Language	:	1
Function	:	LOW, MEDIUM HIGH FOR ALKALINE & ACIDIC
Input Power	:	230V
Standard Power	:	24VDC 3AMP

SWK 61R

The Mystic Hydroheal Model (RO+Ionizer)

Introducing The Mystic Hydroheal Model - your ultimate solution for alkaline drinking water. Our state-of-the-art technology guarantees the conversion of ordinary tap water into alkaline water, delivering not only superior taste but also numerous health advantages.

Product Specifications

Screen	:	TouchPad Display (100*50mm)
PH Level	:	4.5-10.5
Input TDS	:	50-150
Wattage	:	0-400 (W)
Water Flow	:	70-80 LPH
Ease of Use	:	Fully automatic, simple to operate
Language	:	1
Function	:	LOW, MEDIUM HIGH FOR ALKALINE & ACIDIC
Input Power	:	230V
Tank Capacity	:	12L

SWK 61

The Aqua Elevate Model

Presenting the Aqua Elevate Model featuring 7 plates - your ultimate solution for alkaline drinking water. Our cutting-edge technology ensures the transformation of regular tap water into alkaline water, offering not just exceptional taste but also a multitude of health benefits.

Product Specifications

Screen	:	Graphic Display (80*90mm)
PH Level	:	4.5-9.5
Input TDS	:	50-150
Wattage	:	0-400 (W)
Water Flow	:	50-60 LPH
Ease of Use	:	Fully automatic, simple to operate
Language	:	1
Function	:	LOW, MEDIUM HIGH FOR ALKALINE & ACIDIC
Input Power	:	230V
Standard Power	:	24VDC, 3AMP



SNOWIS[®]
FOR BETTER HEALTH

For More Details Please Contact



A Division of
EControl Devices Pvt Ltd.
Smart Solutions For Better Living

info@snowis.in

www.snowis.in